

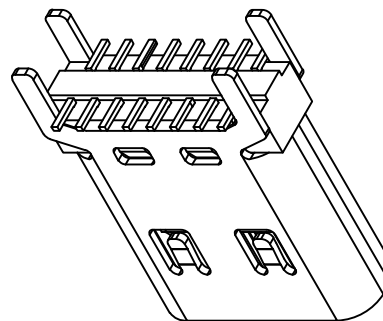

REV	DESCRIPTION	DATE	APPROVED
A	新板发行	2023.05.05	HHM

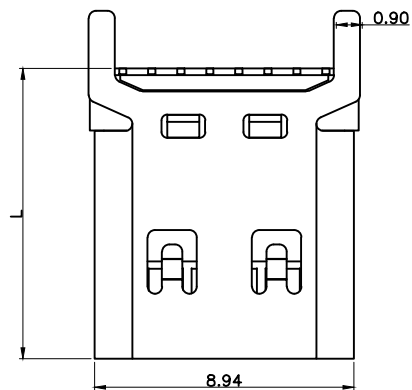

**NOTE:**  
备注:

**1.MATERIAL SPECIFICATION:**  
1.材料规格:  
1-1.HOUSING:HIGH TEMPERATURE RESISTANT PLASTIC,UL94 V-0  
1-1.胶芯材料: 高温塑胶, 防火等级UL94 V-0  
1-2.TERMINAL: COPPER ALLOY  
1-2.端子材料: 铜合金  
1-3.FRONT SHELL: STAINLESS STEEL  
1-3.外壳材料: 不锈钢  
1-4.MID PLATE: STAINLESS STEEL  
1-4.中夹片: 不锈钢

**2.PLATING SPECIFICATION:**  
2.电镀规格:  
2-1.TERMINAL:  
2-1.端子:  
Ni 30u" MIN. UNDER PLATED OVER ALL.  
镀镍底 30u" MIN.  
Au PLATED Golden Flash OVER Ni  
表面刷金 Golden Flash  
2-2.FRONT SHELL:  
2-2.外壳:  
Ni 30u" MIN. PLATED OVER ALL.  
镀镍底 30u" MIN.

**3.MECHANICAL PERFORMANCE,**  
3.机械性能:  
3-1.INSERTION FORCE: 0.5~2.0kgf.  
3-1.插入力: 0.5~2.0kgf.  
3-2.REMOVAL FORCE: 0.6kgf~2.0kgf.  
3-2.拔出力: 0.6kgf~2.0kgf.  
3-3.DURABILITY: 10000 CYCLES.  
3-3.插拔寿命: 10000次

**4.ELECTRICAL PERFORMANCE,**  
4.电气性能:  
4-1. VOLTAGE RATING: 48V DC/AC  
4-1. 额定电压: 48V DC/AC  
CURRENT RATING: 5A  
额定电流: 5.0A  
4-2. LLCR: 50mΩ/PIN MAX.  
4-2. 接触阻抗: 50mΩ/PIN MAX.  
4-3.INSULATION RESISTANCE: 100MΩ MIN  
4-3. 绝缘阻抗: 100MΩ MIN  
4-4.DIELECTRIC WITHSTAND VOLTAGE,AC 100V FOR 1 MINUTE.  
4-4. 耐电压: AC 100V FOR 1 MINUTE.

**5. ENVIRONMENTAL PERFORMANCE:**  
5. 环境特性:  
OPERATING TEMPERATURE: -25°C~+85°C.  
工作温度: -25°C~+85°C.

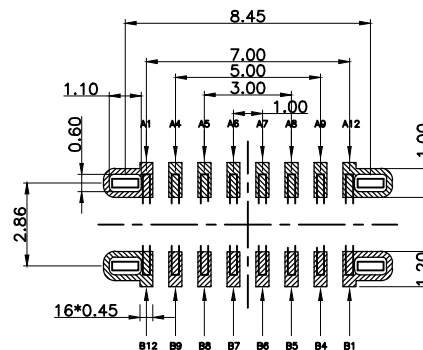
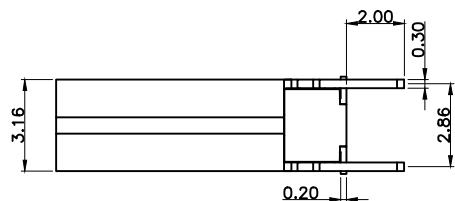
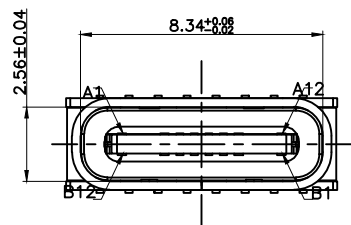

RECOMMENDED P.C.B. LAYOUT  
TOLERANCE UNSPECIFIED ±0.05mm

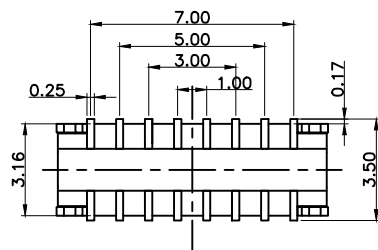
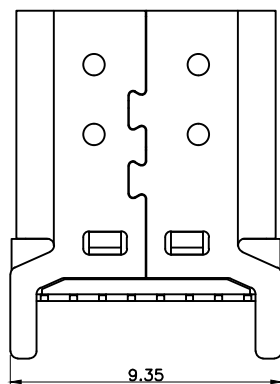

A1	GND	B12	GND
A2		B11	
A3		B10	
A4	VBUS	B9	VBUS
A5	CC1	B8	SBU2
A6	DP1	B7	DN2
A7	DN1	B6	DP2
A8	SBU1	B5	CC2
A9	VBUS	B4	VBUS
A10		B3	
A11		B2	
A12	GND	B1	GND

CUSTOMER DRAWING		
UNITS	SCALE	SHEET
mm	1:1	1 OF 1
PROJECTION:		DRAW:
		DAP
GENERAL TOLERANCE		CHECK:
.000	±0.02	HWT
.00	±0.10	APPD:
.0	±0.20	HHM
.0	±2°	
.00	±1°	

铭创科技(东莞)有限公司  
Mingchuang Technology (Dongguan) Co., Ltd

TITLE  
TYPE C母座16PIN 立式四脚插板SMT  
L=10.0 三模 带中夹片 有弹

MAT'L  
SEE TABLE

FINISH  
SEE TABLE

DWG. NO.  
A011646A

PART NO.  
\_\_\_\_\_

SIZE  
A4

L = 10.00