

3D VIEW

RECOMMENDED P.C.B. LAYOUT  
TOLERANCE UNSPECIFIED ±0.05mm

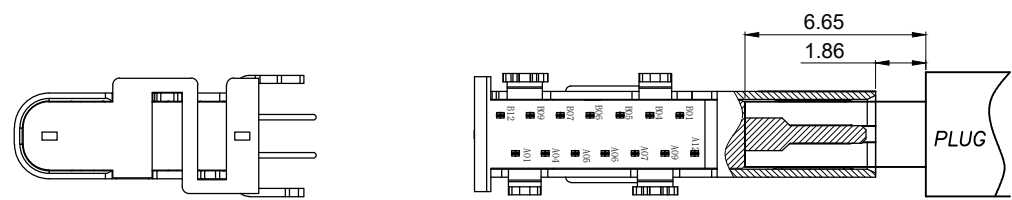
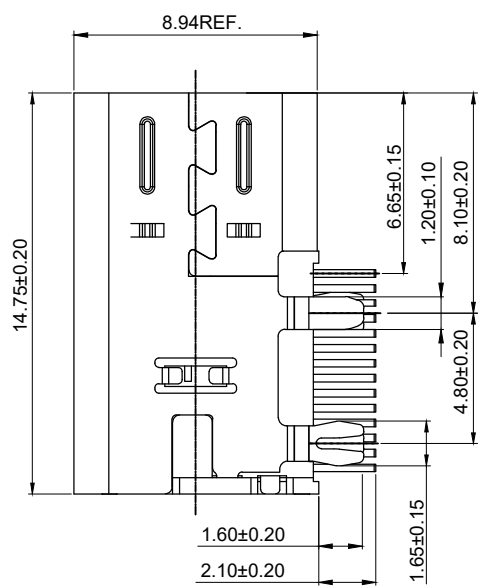
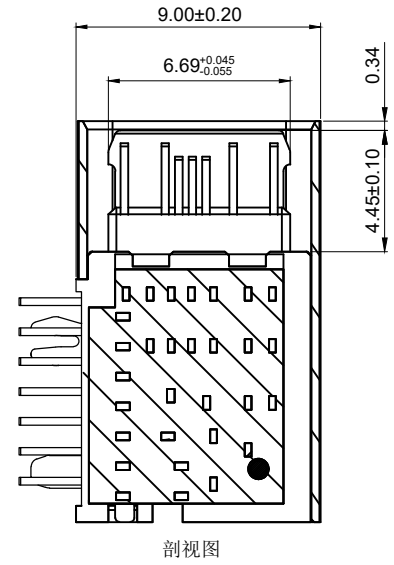
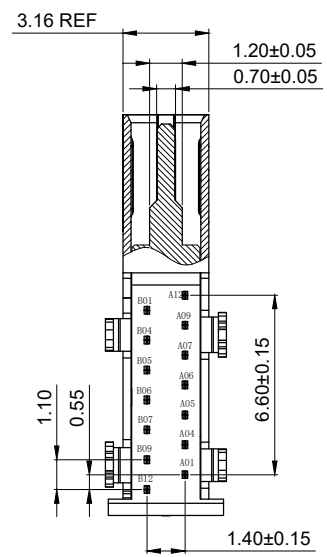

SPECIFICATION:

- ELECTRICAL:
  - CURRENT RATING:5.0A;
  - CONTACT RESISTANCE:40mΩ Max;
  - DIELECTRIC WITHSTANDING VOLTAGE:100V AC;
  - INSULATION RESISTANCE:100 MΩ MIN;
- MECHANICAL:
  - MATING FORCE:5~20N;
  - UNMATING FORCE:8~20N;
  - DURABILITY:10000 CYCLES;6~20N AFTER DURABILITY TEST;
- MATERIAL:
  - HOUSING&MOLDING: BLACK LCP UL94V-0;
  - TERMINAL:C2680 T=0.20mm;
  - SHELL:SUS304 T=0.30mm;
  - MID PLATE:SUS304 T=0.30mm;
- PLATING SPECIFICATION:
  - TERMINAL:CONTACT POINT GOLD PLATED 3u" Min  
PIN WELDING AREA TIN PLATED 80u" Min.
  - NI 40u" Min. UNDER PLATED OVER ALL.
  - SHELL:PLATED Ni 50u" Min(Salt spray 48H)
- ELECTROPLATED PRODUCTS NEED TO UNDERGO TIN ADHESION TESTING: THE TIN ADHESION AREA SHOULD REACH OVER 95%.
- SMT REFLOW SOLDERING (PEAK VALUE 260 °C ± 5 ° C) SHALL BE FREE OF BLISTERING, GLUE MELTING AND POOR COLOR CHANGE (DEFORMATION WITHIN TOLERANCE)
- OPERATING TEMPERATURE: -40°C~+85°C

A1	GND	B12	GND
A4	VBUS	B9	VBUS
A5	CC1		
A6	D+	B7	Dn2
A7	D-	B6	Dp2
		B5	CC2
A9	VBUS	B4	VBUS
A12	GND	B1	GND
PIN	SIGNAL NAME	PIN	SIGNAL NAME

CUSTOMER DRAWING

UNITS mm	SCALE 1:1	SHEET 1 OF 2
PROJECTION: 	DRAW: DAP	
GENERAL TOLERANCE X. ±0.25 X.x ±0.20 X.xx ±0.15 X.xxx ±0.10 ANGLES ±2°	CHECK: HWT	APPD: HHM

铭创科技 (东莞) 有限公司  
Mingchuang Technology (Dongguan) Co., Ltd

TITLE TYPE C母座14PIN 侧插四脚交叉小脚 鱼叉脚DIP L=14.75 CH=5.06	
MAT'L SEE TABLE	FINISH SEE TABLE
DWG. NO. A031410B	PART NO. _____ SIZE A4

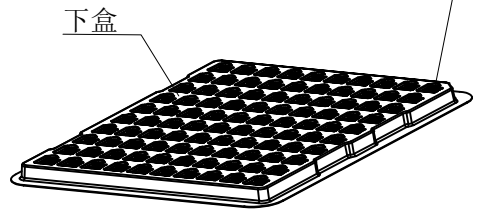
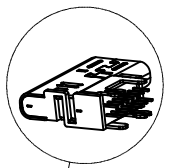
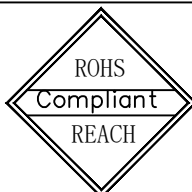

① 100Pcs/盒

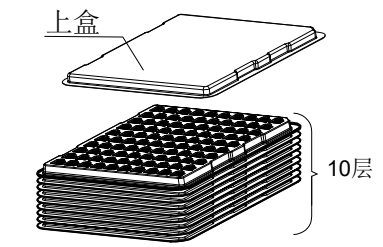

② 25层/叠 (2.5K)

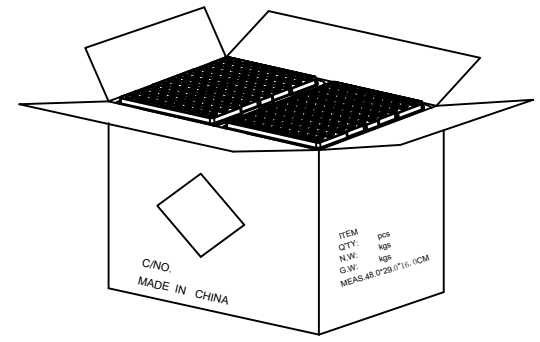
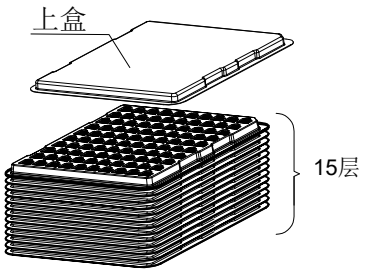
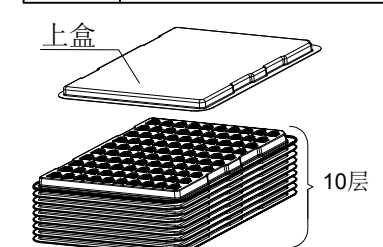

③ 2叠x2=5K/箱

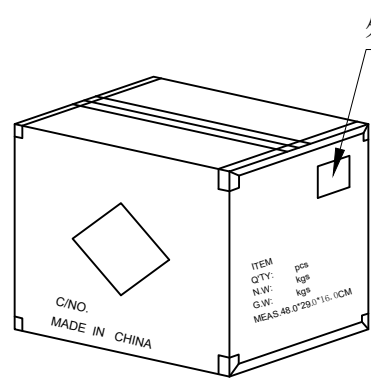

⑥ 依图示粘贴产品或RoHS标签。

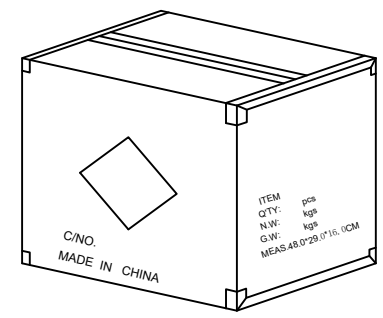

⑤ 外箱用透明胶纸带封“工”字型。

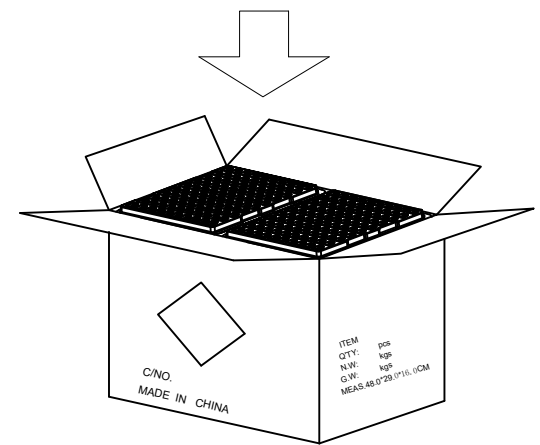

④ 每箱竖放25盒\*2, 若尾数箱在空间处加装填充物。

REV	DESCRIPTION	DATE	APPROVED

- 备注:
1. 每盒装成品100Pcs;
  2. 2叠15层+2叠10层, 每叠顶面加一个上盖;
  3. 每箱装50盒(5K);
  4. 外箱尺寸与规格: 48.0\*29.0\*16.0CM
  5. 外箱用透明胶纸带封“工”字型;

序号	物料名称	物料编号	规格	描述
04	纸箱	B-05-0017	480mm*290mm*160mm	1 PCS
03	上盖	B-01-0018	PET透明 T0.50*L280*W230*H11mm	4 PCS
02	下盒	B-01-0017	PET透明 T0.45*L280*W230*H11mm	50 PCS
01	连接器	A031410B	14PIN, DIP	5000 PCS

CUSTOMER DRAWING		
UNITS mm	SCALE 1:1	SHEET 1 OF 2
PROJECTION: 	DRAW: DAP	
GENERAL TOLERANCE X. ±0.25 X.x ±0.20 X.xx ±0.15 X.xxx ±0.10 ANGLES ±2°	CHECK: HWT	
	APPD: HHM	

铭创科技(东莞)有限公司 Mingchuang Technology (Dongguan) Co., Ltd		
TITLE TYPE C母座14PIN 侧插四脚交叉小脚 鱼叉脚DIP L=14.75 CH=5.06		
MAT'L SEE TABLE	FINISH SEE TABLE	
DWG. NO. A031410B	PART NO.	SIZE A4