

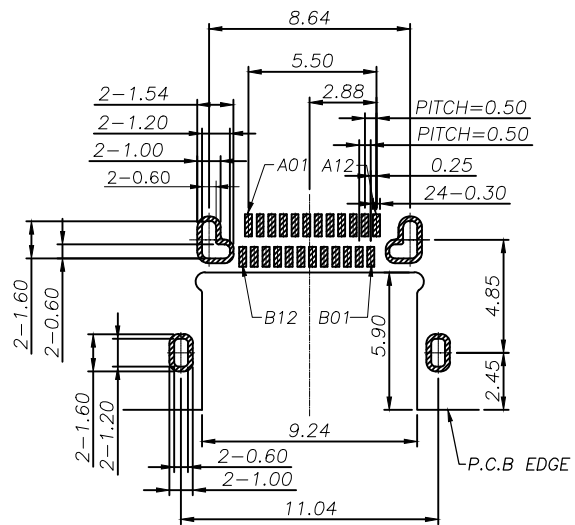

REV	DESCRIPTION	DATE	APPROVED

- SPECIFICATION:**
- ELECTRICAL:**
    - CURRENT RATING:5A;
    - CONTACT RESISTANCE:40mΩ Max;
    - DIELECTRIC WITHSTANDING VOLTAGE:100V AC;
    - INSULATION RESISTANCE:100 MΩ MIN;
  - MECHANICAL:**
    - MATING FORCE:5~20N;
    - UNMATING FORCE:8~20N;
    - DURABILITY:10000 CYCLES;6~20N AFTER DURABILITY TEST;
  - MATERIAL:**
    - HOUSING&MOLDING:BLACK LCP UL94V-0;
    - TERMINAL:C18400 T=0.12mm;
    - SHELL:SUS304 T=0.30mm;
    - GROUNDING STRIP: SUS316 T=0.10mm;
    - MID PLATE:SUS301 T=0.15mm;
  - PLATING SPECIFICATION:**
    - TERMINAL:CONTACT POINT GOLD PLATED 3u "MIN PIN WELDING AREA GOLD PLATED 1u" MIN.
    - NI 40u" MIN. UNDER PLATED OVER ALL.
    - SHELL:PLATED Ni 50u" MIN(Salt spray 48H)
  - ELECTROPLATED PRODUCTS NEED TO UNDERGO TIN ADHESION TESTING: THE TIN ADHESION AREA SHOULD REACH OVER 95%.**
  - SMT REFLOW SOLDERING (PEAK VALUE 260 °C ± 5 ° C) SHALL BE FREE OF BLISTERING, GLUE MELTING AND POOR COLOR CHANGE (DEFORMATION WITHIN TOLERANCE)**
  - OPERATING TEMPERATURE: -40°C~+85°C**

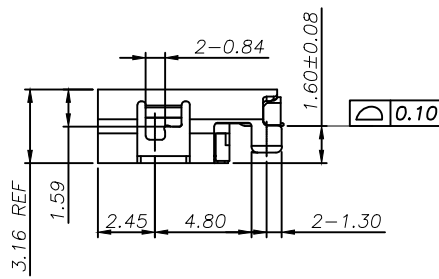
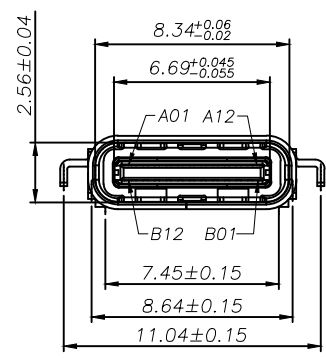
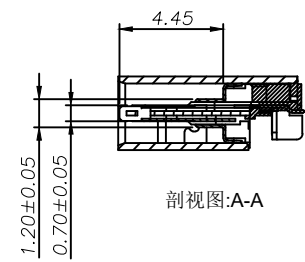
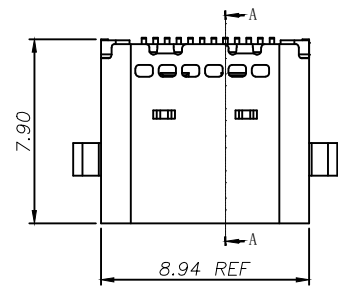

RECOMMENDED P.C.B. LAYOUT (俯视图)  
TOLERANCE UNSPECIFIED ±0.05mm

A1	GND	B12	GND
A2	TX1+	B11	RX1+
A3	TX1-	B10	RX1-
A4	VBUS	B9	VBUS
A5	CC1	B8	SBU2
A6	D+	B7	D-
A7	D-	B6	D+
A8	SBU1	B5	CC2
A9	VBUS	B4	VBUS
A10	RX2-	B3	TX2-
A11	RX2+	B2	TX2+
A12	GND	B1	GND
PIN	SIGNAL NAME	PIN	SIGNAL NAME

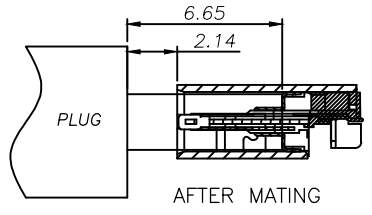
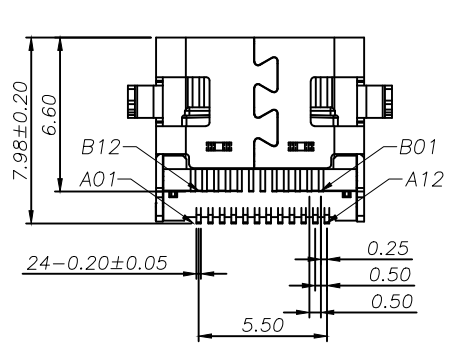

CUSTOMER DRAWING		
UNITS mm	SCALE 1:1	SHEET 1 OF 2
PROJECTION: 	DRAW: DAP	
GENERAL TOLERANCE X. ±0.25 X.x ±0.20 X.xx ±0.15 X.xxx ±0.10 ANGLES ±2°	CHECK: HWT	APPD: HHM

铭创科技 (东莞) 有限公司 Mingchuang Technology (Dongguan) Co., Ltd		
TITLE TYPE C母座24PIN 沉板0.8 四脚插板 SMT L=7.9		
MAT'L SEE TABLE	FINISH SEE TABLE	
DWG. NO. A032415A	PART NO.	SIZE A4



REV	DESCRIPTION	DATE	APPROVED

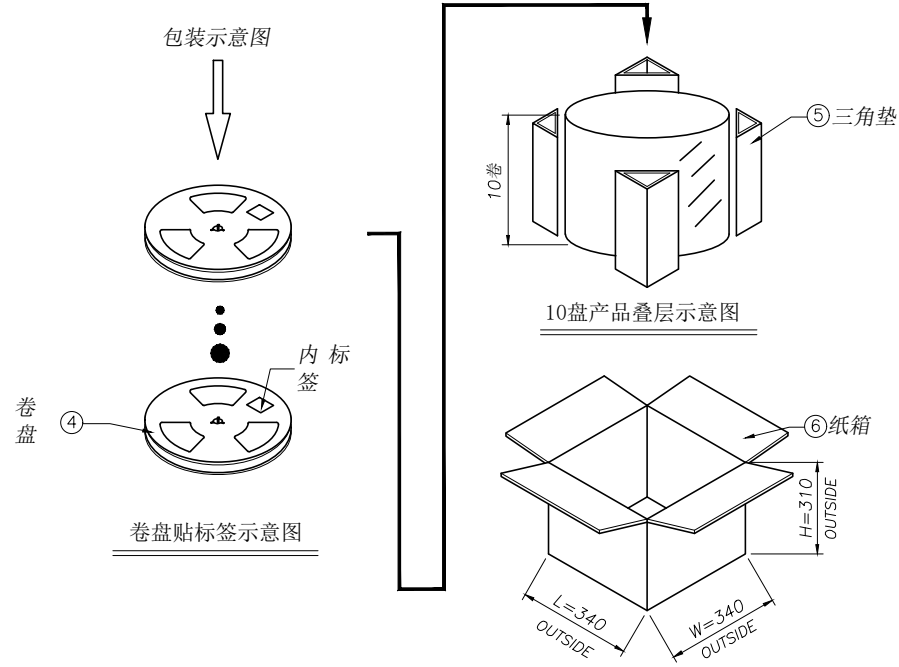
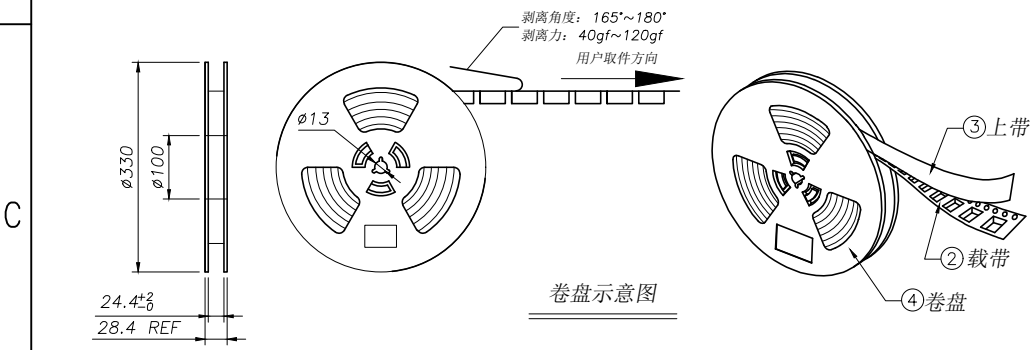
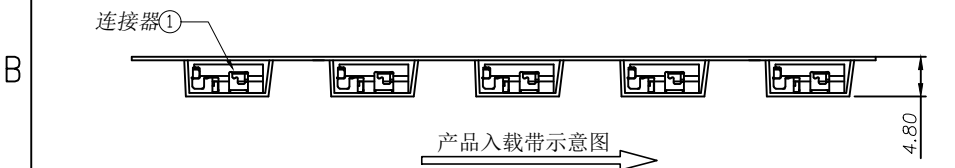
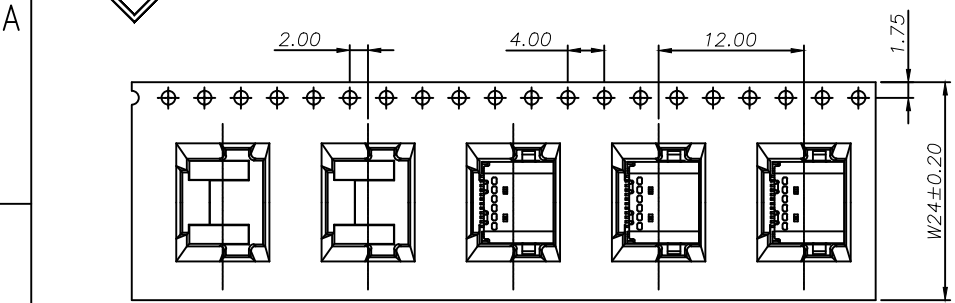

- 技术要求:
- 载带首尾各留出 20PCS 空格 不装产品;
  - 每穴放置 1PCS 产品, 每卷装 1000PCS 产品, 放置方式如图所示;
  - 将包装好的产品: 每盘必需贴上内标签; 将贴好内标签的产品每 10 盘堆叠.
  - 在纸箱四角垫上 4 个三角垫, 然后把装好产品的卷盘放入纸箱中, 最后用胶带封箱; (如客户有要求, 请按客户要求包装出货)
  - 上带与载带的剥离力: 40gf~120gf, 跳动量在 30gf 内; (剥离角度: 165°~180°, 剥离速度: 250~300mm/min)
  - 产品符合 RoHS 环保标准要求.

06	纸箱	B-05-0011	340mm*340mm*310mm	1 PCS
05	三角垫	/	300mm*260mm*7mm	4 PCS
04	卷盘	/	D=330mm, d=100mm, H=28.5mm	10 PCS
03	上带	/	W=21.3mm, T=0.05mm	12500 mm
02	载带	B-03-0001	W=24mm, T=0.30mm, P=16.0mm	12500 mm
01	连接器	A032415A	24PIN, SMT	10000 PCS
序号	物料名称	物料编号	规格	描述

CUSTOMER DRAWING			铭创科技 (东莞) 有限公司 Mingchuang Technology (Dongguan) Co., Ltd		
UNITS mm	SCALE 1:1	SHEET 1 OF 2	TITLE TYPE C 母座 24PIN 沉板 0.8 四脚插板 SMT L=7.9		
PROJECTION: 		DRAW: DAP	MAT'L SEE TABLE		FINISH SEE TABLE
GENERAL TOLERANCE X. ±0.25 X.x ±0.20 X.xx ±0.15 X.xxx ±0.10 ANGLES ±2°		CHECK: HWT	DWG. NO. A032415A		PART NO. _____
		APPD: HHM	SIZE A4		