



REV	DESCRIPTION	DATE	APPROVED

SPECIFICATION:

- ELECTRICAL:
  - CURRENT RATING:5A;
  - CONTACT RESISTANCE:40mΩ Max;
  - DIELECTRIC WITHSTANDING VOLTAGE:100V AC;
  - INSULATION RESISTANCE:100 MΩ MIN;
- MECHANICAL;
  - MATING FORCE:5~20N;
  - UNMATING FORCE:8~20N;
  - DURABILITY:10000 CYCLES;6~20N AFTER DURABILITY TEST;
- MATERIAL:
  - HOUSING&MOLDING: LCP BLACK UL94V-0;
  - TERMINAL:C7025 T=0.15mm;
  - SHELL:SUS304 T=0.30mm;
  - MID PLATE:SUS304 T=0.20mm;
- PLATING SPECIFICATION:
  - TERMINAL:CONTACT POINT GOLD PLATED 3u "Min  
PIN WELDING AREA GOLD PLATED 1u" Min.
  - NI 40u"Min. UNDER PLATED OVER ALL.
  - SHELL:PLATED Ni 50u" Min(Salt spray 48H)
- ELECTROPLATED PRODUCTS NEED TO UNDERGO TIN ADHESION TESTING: THE TIN ADHESION AREA SHOULD REACH OVER 95%.
- SMT REFLOW SOLDERING (PEAK VALUE 260 °C ± 5 ° C) SHALL BE FREE OF BLISTERING, GLUE MELTING AND POOR COLOR CHANGE (DEFORMATION WITHIN TOLERANCE)
- OPERATING TEMPERATURE: -40°C~+85°C

A1	GND	B12	GND
A4	VBUS	B9	VBUS
A5	CC1	B7	Dn2
A6	D+	B6	Dp2
A7	D-	B5	CC2
A9	VBUS	B4	VBUS
A12	GND	B1	GND
PIN	SIGNAL NAME	PIN	SIGNAL NAME

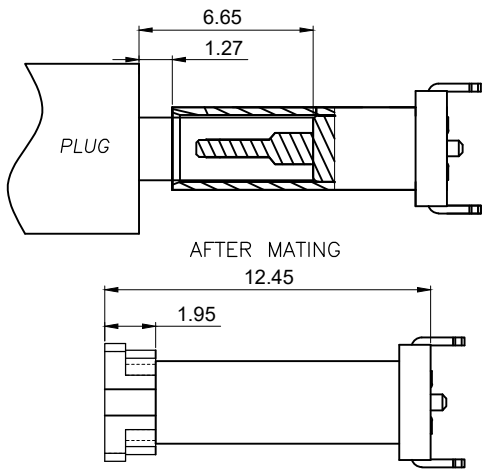
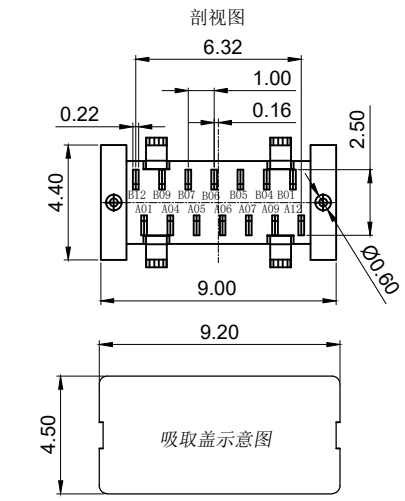
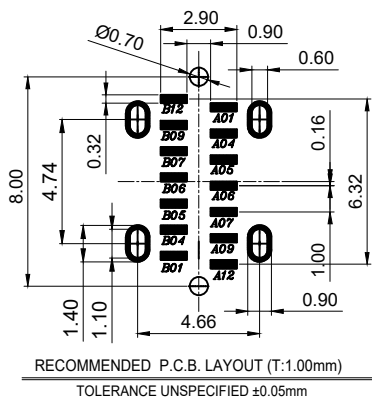
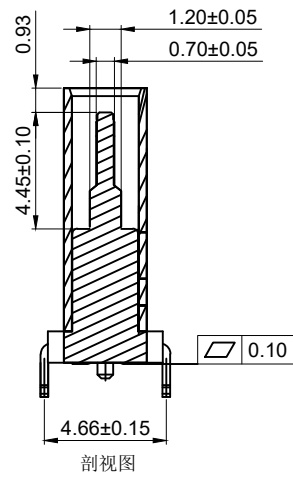
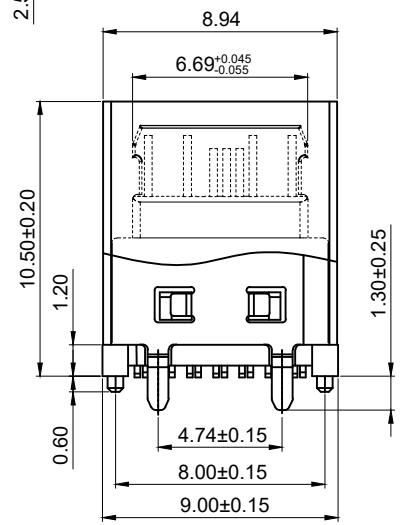
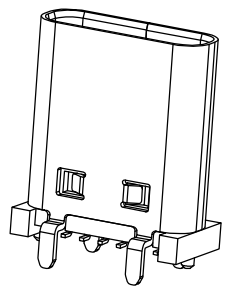
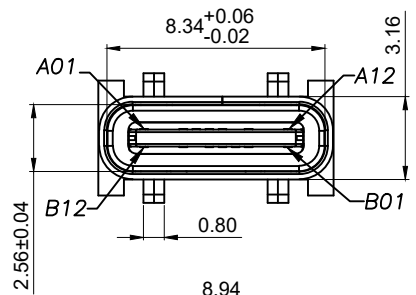

CUSTOMER DRAWING		
UNITS mm	SCALE 1:1	SHEET 1 OF 2
PROJECTION: 	DRAW: DAP	
GENERAL TOLERANCE X. ±0.25 X.x ±0.20 X.xx ±0.15 X.xxx ±0.10 ANGLES ±2°	CHECK: HWT	APPD: HHM

铭创科技 (东莞) 有限公司 Mingchuang Technology (Dongguan) Co., Ltd		
TITLE TYPE C母座14PIN 立式四脚插版 SMT L=10.5 A款		
MAT'L SEE TABLE	FINISH SEE TABLE	
DWG. NO. A031401A	PART NO.	SIZE A4

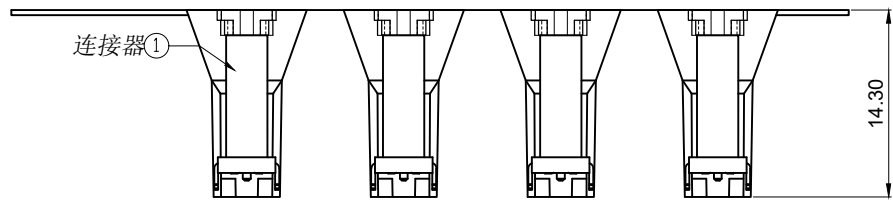
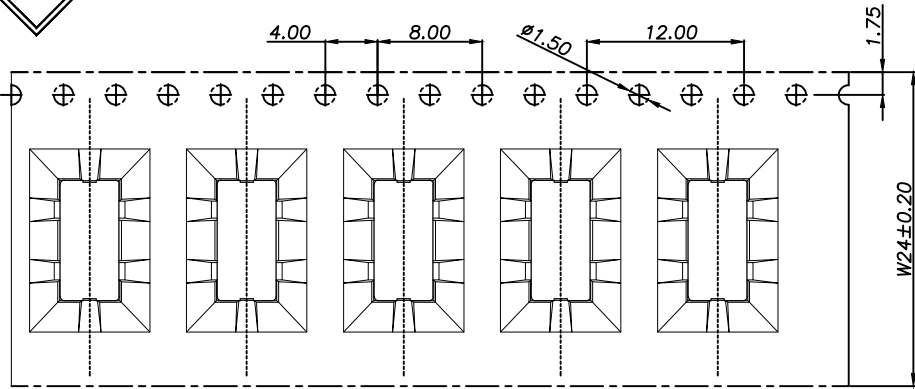

产品入载带示意图

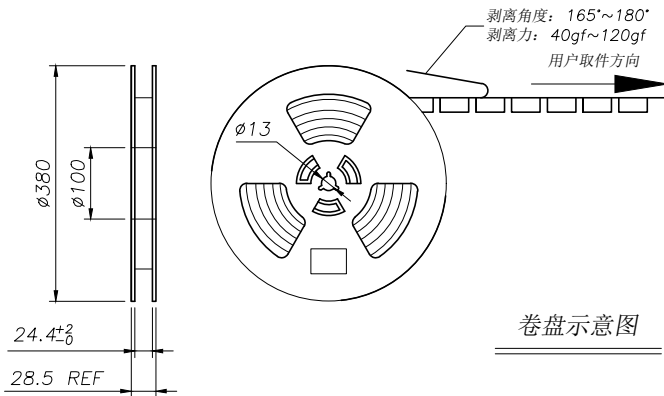

卷盘示意图

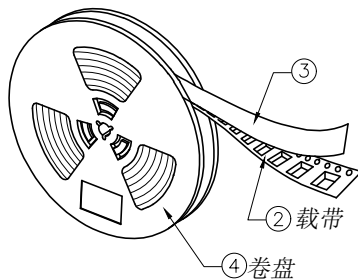

卷盘

卷盘贴标签示意图

包装示意图

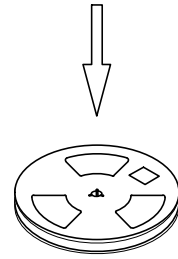

内标

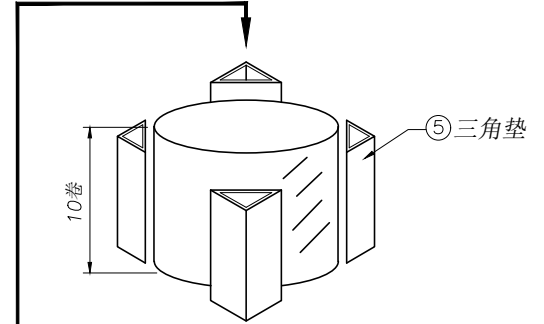

10盘产品叠层示意图

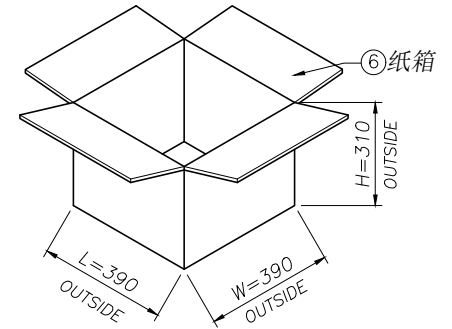

技术要求:

1. 载带首尾各留出 10PCS 空格 不装产品;
2. 每穴放置 1PCS 产品, 每卷装 500PCS 产品, 放置方式如图所示;
3. 将包装好的产品; 每盘必需贴上内标签; 将贴好内标签的产品每 10 盘堆叠.
4. 在纸箱四角垫上 4 个三角垫, 然后把装好产品的卷盘放入纸箱中, 最后用胶带封箱; (如客户有要求, 请按客户要求包装出货)
5. 上带与载带的剥离力: 40gf~120gf, 跳动量在 30gf 内; (剥离角度: 165°~180°, 剥离速度: 250~300mm/min)
6. 产品符合 RoHS 环保标准要求.

CUSTOMER DRAWING

UNITS mm	SCALE 1:1	SHEET 2 OF 2
PROJECTION: 	DRAW: DAP	
GENERAL TOLERANCE X. ±0.25 X.x ±0.20 X.xx ±0.15 X.xxx ±0.10 ANGLES ±2'	CHECK: HWT	APPD: HHM

铭创科技 (东莞) 有限公司

Mingchuang Technology (Dongguan) Co., Ltd

TITLE TYPE C 母座 14PIN 立式四脚插板 SMT L=10.5 A 款		
MAT'L SEE TABLE	FINISH SEE TABLE	
DWG. NO. A031401A	PART NO. _____	SIZE A4

06	纸箱	B-05-0012	390mm*390mm*310mm	1 PCS
05	三角垫	/	300mm*260mm*7mm	4 PCS
04	卷盘	/	D=380mm, d=100mm, H=28.5mm	10 PCS
03	上带	/	W=20.7mm, T=0.05mm	6240 mm
02	载带	B-03-0037	W=24mm, T=0.50mm, P=12.0mm	6240 mm
01	连接器	A031401A	14PIN, SMT	5000 PCS
序号	物料名称	物料编号	规格	描述